

The Historical Galileo telescope

Kit for a cardboard replica of the only surviving telescope made by Galileo himself.

In 1608 Hans Lippershey, spectacle maker from the Dutch city of Middelburg, invented a telescope with a magnification of about 3 times. At the eyepiece end was a concave lens (curved inwards, used for correcting short sight) and at the end towards the object being viewed was a convex lens (curved outwards, for correcting long sight). However, he was not granted a patent as other spectacle makers were already supplying telescopes. The news of this invention spread rapidly through the whole of Europe. Galileo Galilei (1564-1642), professor of mathematics at Padua, was immediately intrigued by this. Even before the first Dutch telescopes arrived in Italy, he had built his own telescope with a magnification of about 4. He at once began to increase their power and successively built telescopes with magnifications of 8, 13, and in later years as much as 33. He ground the lenses himself.

At the beginning of the 17th century, learned people were still arguing about whether the earth was at the centre of the universe, or whether it was indeed the sun, as Kopernicus maintained. However, they had no proof of either of these. The astronomers were convinced they knew all the planets and had catalogued all the fixed stars, and that even the most precise observations would not bring them anything new, apart from occasional comets and novae.

It is to Galileo's great credit that he nevertheless turned his telescope to the skies. What he saw there was truly astonishing. The moon was covered with craters, the Milky Way contained millions of stars, Venus had phases, and above all: there were moons circling round the planet Jupiter. As early as 1610 he published his sensational discoveries from that year and the previous year in a work entitled "Sidereus

Nuncius" (sidereal messenger). That was the start, not only of a new astronomy, but of a new view of the world, that still shapes us today.

Even though the first telescope was invented in Holland: Galileo deserves the credit for recognising it as a scientific instrument and for perfecting it. This makes it well justified to call a telescope of this type a "Galilean telescope".



Surface of the Moon from Sidereus Nuncius, 1610

The galilean arrangement of the lenses gives an upright image, which is a great advantage. The drawback is, however, more serious: The greater the magnification, the smaller is the visible part of the image. With a magnification of 30 times, it is so small that an observer can hardly be sure what he is in fact seeing. We can have a great respect for the discoveries that Galileo made despite this.

Galileo's contemporary Johannes Kepler, the great mathematician and astronomer, suggested a different lens arrangement: Both lenses, including the smaller ocular lens, should be convex (curved outwards).

The disadvantage that the image is inverted is not so important in astronomy and would be more than compensated by the greater field of view and higher magnifications. Apart from opera glasses, practically all refracting telescopes (i.e. using only lenses) are designed this way; binoculars have extra optics that turn the image the right way up.

About this historical replica:

Galileo built well over a hundred telescopes, but only two have survived, and they can be seen today in the Museo di Storia della Scienza (science history museum) in Florence: A rather plain working telescope with 14 times magnification, and one covered with costly gold-embossed leather, that is certainly from his hand. It was built towards the end of 1609 and intended for Cosimo II in Florence. This telescope is the model for this kit.

The overall length and the focal length of the objective lens of the cardboard replica are, at 78 cm, each 20 cm shorter than the original. This difference does not affect the authenticity of the cardboard replica, as no two of Galileo's telescopes had the same length and optical performance. The shortening makes the telescope easier to handle and the magnification, reduced to 12 times, gives a considerable increase in the field of view, which is still rather small. Since the ocular lens of the original was replaced in the 19th century, we can only estimate the original magnification. It was probably around 20 times. With this historical galilean telescope you have a unique opportunity to look over the shoulder of the great researcher and to appreciate his discoveries with the same means, which seem very modest today but were, in the hands of a Galileo, the key to a new view of the universe.

For assembling the kit you need:

- Ordinary solvent-based general-purpose adhesive. This can be used for all the parts. Do not use a water-based solvent-free adhesive; it will soften the cardboard and gives unwanted edges on the surfaces that have been bent to a round shape. Solvent-based adhesive will also set more quickly and adheres better on the surfaces protected with print varnish.
- A sharp craft knife or a scalpel with a fine point.
- Some clear adhesive tape and masking tape. The masking tape is for holding the round outer casings in position while the adhesive sets. Alternatively a dozen elastic bands could be used.
- A small pair of scissors, perhaps nail scissors, for trimming off excesses.
- A cutting board or mat, such as solid board (not corrugated) or plastic or wood. Self-healing cutting mats are useful, as the material re-closes after each cut.
- A thick black felt marker for colouring the back of some small parts.
- A circular rod, about 20 cm long, and at least 1.5 cm thick, e.g. a

thick felt marker, part of a broom handle or something similar. An alternative is to wrap paper round a thinner rod (or a round pencil) to give it the required thickness. This rod will be used to bend the outer casings into a round shape.

- Fine sandpaper or an emery board to file off protruding card edges.
- Methylated spirit or similar for cleaning the glass lenses.

The instructions use the word OPTION to indicate steps that you can include if you are aiming at perfection, but they are not essential. For this you need:

- A gold marker pen and red and brown felt pens if you would like to colour the white edges of the board that remain visible after assembly.
- Two metal washers \varnothing about 20 mm (external) and \varnothing about 8 mm (internal), if you want to hang the telescope holder on the wall. You can also make suitable washers of plywood or strong cardboard. They reinforce the holes in the rear panel.

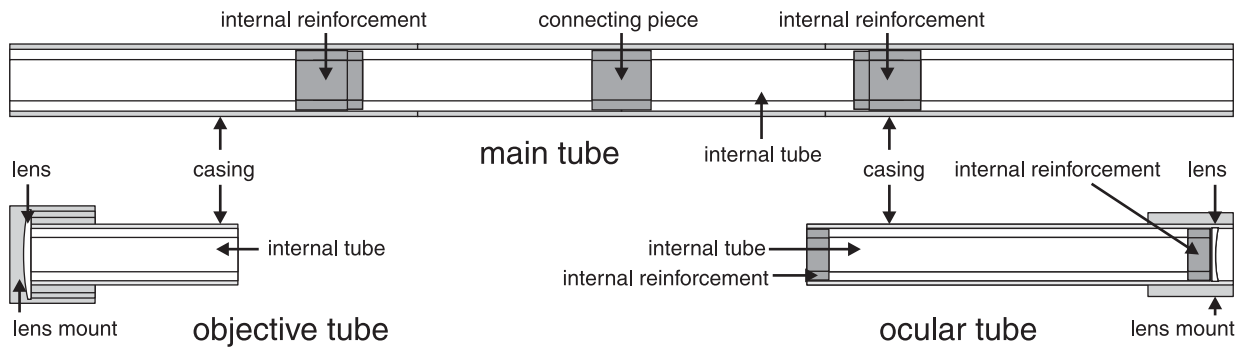

Fig. 1

Hints for successfully assembling the kit

Please read this before you start!

1. The assembly instructions have been divided into 41 small steps, each with a full description. At first sight this looks like a frighteningly large amount of text but it will greatly simplify making your construction work successful because it explains everything. Please read each step fully before you carry it out, and allow yourself enough time.
2. Most of the steps occur repeatedly in a similar form. You will notice that the work is almost self-explanatory after the first few steps.
3. Each part is marked with its name and a part number that consists of a letter and a number. The same letter is used for all the parts of a single sub-assembly. You should preferably detach only those parts that will be needed immediately, or write the part numbers on the back if they are not already printed on that part.
4. Preferably do not tear the parts out of the sheet of cardboard, but use a knife to cut the small connecting pieces so that the edges remain smooth.
5. All fold lines are marked with small perforations. In some cases they are to be bent "forwards", i.e. towards you when you are looking at the printed side, or "backwards", i.e. away from you.
6. The areas to which something will be stuck are usually marked in grey.

This kit contains:

- 6 sheets of punched cardboard, 0.3 mm
- 1 objective lens made of glass, \varnothing 42 mm, focal length 780 mm, plano-convex shape (one flat side, one side curved outwards)
- 1 ocular lens made of glass, \varnothing 25 mm, focal length 65 mm, plano-concave (one flat side, one side curved inwards).

Section A: The objective tube

The objective tube, the ocular tube and the main tube are all constructed in a similar way: First, a piece of cardboard is folded and glued to give a hexagonal internal tube, and then a round bent piece of cardboard is stuck round it as a casing. Together with further internal and external reinforcing items, this gives a strong design like a honeycomb in cross-section (see the section drawing above and Fig. 2). - Initially only the internal tube with flat sides and the round outer casing of the objective tube are made, with the lens mount added later in section E.

Step 1: Bend the internal tube of the objective tube [A1] forwards along all the fold lines to produce a hexagonal (six-sided) tube with a black interior. Stick the rear of the narrow black glue tab onto the grey area marked for glueing on the opposite side so that it is inside the tube.

HINT: Press the tube flat onto the working surface several times, with the glue area underneath. Allow it time to dry.

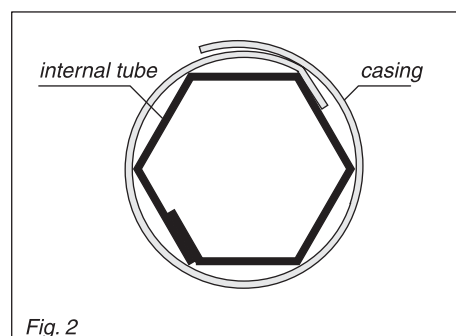

Fig. 2

The objective tube has only an external reinforcement, not an internal one. To ensure that the internal tube retains its hexagonal shape when the outer casing [A2] is stuck on, the two internal reinforcements [B2] and [B3] of the ocular tube are temporarily inserted into it in the next step.

Step 2: Detach the internal reinforcements 1 and 2 of the ocular tube [B2+B3] from

the cardboard and also remove the round discs in the centre. Fold the six tabs forwards and insert the interior reinforcements, without adhesive, about 1 cm (0.4 inch) into the two ends of the objective tube, with the hexagon first, so that the tabs are flush with the edge. They will be removed again after the next step.

Step 3: Detach the outer casing of the objective tube [A2] from the cardboard.

OPTION: Colour the cut edge opposite the glue tab with a felt pen.

Pull the outer casing over a table edge and then roll it on the cylindrical rod

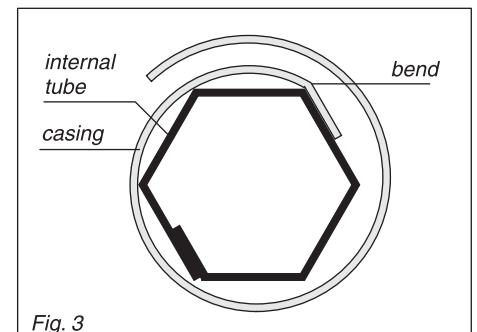

Fig. 3

(broom handle, wrapped pencil etc. described above) to give it a round shape, of course with the printing on the outside.

HINT: If you have several rods of different diameters, use the one with the largest diameter first and then progress to the smaller one. This makes it easier to produce a uniform curvature without creases. Start with a glue tab, marked with a perforation, on the rod and then roll it again with the opposite edge on the inside.

First fold the glue tab of the outer casing forwards and back to make it pliant, and then backwards. Stick it on to one of the hexagon sides so that the bend is exactly along the edge (see Fig. 3) and the casing does not protrude beyond any side of the internal tube (see Fig. 1). Let it dry properly and then, for a test, wrap it around the

internal tube (see Fig. 2). Observe the overlap of about 1 cm on the other side.

Step 4: *HINT: If necessary, roll the casing once more so that the end in particular is properly curved.*

Coat the five free edges of the internal tube with plenty of adhesive and carefully wrap the casing round the internal tube, ensuring that no adhesive gets on to the exterior. The casing forms a cylindrical shape lying on the edges of the internal tube, concealing it fully; only the end is not yet stuck on. Take care to ensure that at the ends of the tube the edges of the internal tube and the edges of the casing are precisely flush. Secure the casing with masking tape or put elastic bands over the casing, so that during drying it is in contact with all the edges. Allow it time to dry. Then remove the masking tape or the elastic bands.

HINT: The masking tape is easily removed from the printed cardboard surface, but at the edges take care to avoid tearing the surface.

Carefully bend up the end of the casing, spread adhesive on the last edge of the internal tube (already covered by the glue flap) and under the edge of the casing, and fix them again. After drying, remove both internal reinforcements from the internal tube. The objective tube will now keep its round shape.

Section B: The ocular tube

In the case of the ocular tube, again only the internal tube with the outer casing is completed initially, because it is needed as a temporary internal support in the subsequent assembly of the main tube. The lens mount is not attached until later in Section F. Unlike the main tube, the circular outer casing is a little longer than the flat-sided internal tube and so projects beyond it at one end.

Step 5: Stick the hexagonal internal tube of the ocular tube [B1] together in the same way as for the objective tube. Using

a felt pen, apply black colour to the hexagonal rear sides of both internal reinforcements 1 and 2 of the ocular tube [B2+B3], that were previously used as temporary internal supports in the objective tube. Then stick one internal reinforcement in each end of the ocular tube in such a way that the glue tabs with their white reverse sides are against the inside of the tube and the blackened hexagon is precisely flush with the edge of the tube (see Fig. 4). Press the tabs firmly onto the tube wall, e.g. with a pencil held through the hole in the hexagon.

Step 6: Detach the outer casing of the ocular tube [B4] from the cardboard.

OPTION: Colour the cut edge opposite the glue tab.

Notice that on one side of the glue tab a 10 mm wide grey-printed piece is separated from the glue tab by a cut which will not be folded like the rest of the tab. The outer casing will extend beyond the internal tube on one side by these 10 mm. Bend the outer casing to be round as in Step 3, fold the glue tab forwards and back and then backwards, and stick it onto the internal tube in such a way that the fold is precisely on one of the edges and the black-leather printed end of the outer casing ends exactly at the end of the internal tube. This way, the 10 mm wide grey edge protrudes at the other end.

Step 7: Now proceed the same way with the outer casing of the ocular tube as was done for the objective tube in Step 4: Apply adhesive to the edges of the internal tube and wrap the casing around the internal tube so that it can stick firmly to the edges and remain circular on the outside. Ensure that at one end the edges of the internal tube and the casing are accurately together, while at the other end the round casing protrudes. Fix the casing in position while the glue dries. Finally, also glue the end edge of the casing and allow it to dry fully while held in place.

Section C: The internal tube of the main tube

The main tube is also constructed from a hexagonal internal tube and a circular casing. However, it has a somewhat greater diameter and, because of its greater length, it is composed of several sections.

Step 8: Fold and stick together the internal tubes of the main tube [C1+C2] in the same way as you have already done for the internal tubes of the objective tube and the ocular tube, forming two hexagonal tubes. Both parts have grey markings at one end on the inside. Use a pencil to mark a cross on the outside at this end, exactly where the glue tab is on the inside.

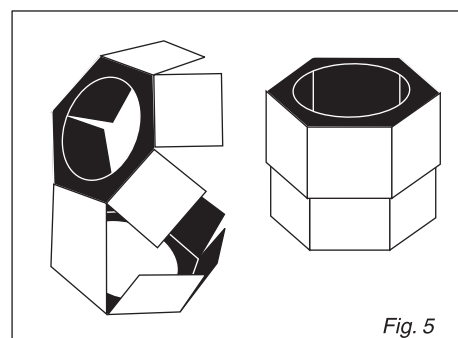

Fig. 5

Step 9: Remove the two circular cutouts from the internal reinforcement 1 of the main tube [C3] and bend all the tabs forwards. Stick the five wholly black tabs with their white rear sides onto the grey glue areas of the other five tabs to give a small hexagonal block (see Fig. 5). It has a black internal surface and a white exterior. Apply black colour to both hexagons at the ends of the block. Do the same with the internal reinforcement 2 of the main tube [C4]. Allow it time to dry.

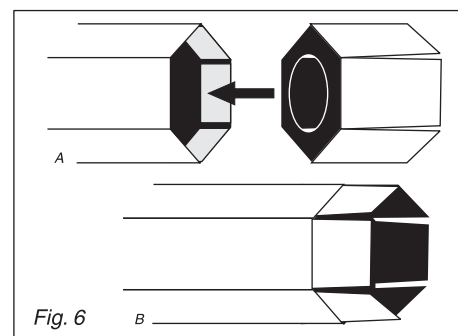

Fig. 6

Step 10: Without using adhesive, push one of the internal reinforcements into each of the two internal tubes of the main tube, approximately to the centre, perhaps with the help of the ocular tube.

HINT: To make them hold in the interior without slipping, bend the tabs that have been glued together outwards a little.

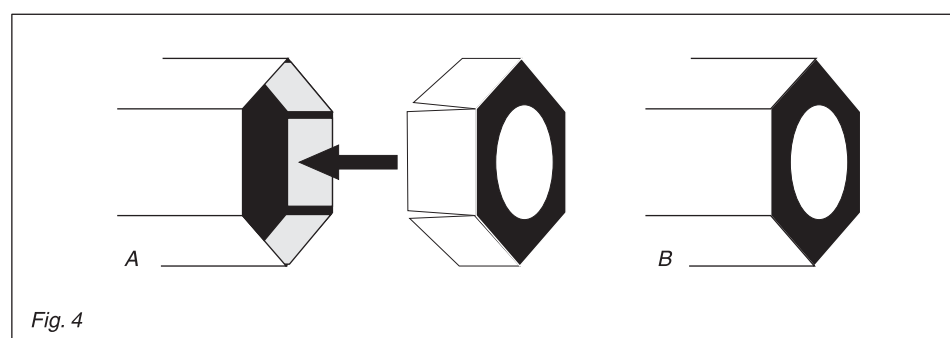

Fig. 4

Step 11: Remove the circular cutout from the connecting piece of the main tube's internal tube [C5], bend the six tabs forwards and colour the back of the white hexagon black. Then push the connecting piece into the end of the main tube's internal tube that has the grey glue markings on the border inside. Push it in with the hexagon first, but only so far that the tabs remain half protruding. Glue the tabs of the connecting piece firmly in this position. Press well and allow enough time to dry (see Fig. 6).

Step 12: Place the other tube, initially without adhesive, onto the glue tabs that protrude from the other internal tube, again with the end that has the internal glue markings. Ensure that the marked crosses (see Step 8) are opposite each other. Pull the tubes apart again, put plenty of adhesive onto the glue markings and stick the tubes together in the position just tested.

HINT: First bend the glue tabs outwards a little so that they press against the interior wall on their own.

Now lay the internal tube, now over 57 cm (22 in.) in length, on a flat surface and check that it is perfectly straight, without a kink, and the two halves abut each other without a gap.

Section D: **The main tube outer casing**

The outer casing of the main tube consists of 3 parts of equal width, that have similar but not identical printing. To facilitate distinguishing among them, it is a good idea to write their names and numbers on the back before detaching them. The centre part covers the join between the two halves of the internal tube.

Step 13: Detach the outer casing for the objective side of the main tube [C6] from the cardboard, use the rod to give it a curved shape, and bend the glue tab forwards and back and then backwards.

OPTION: Colour the cut edge opposite the glue tab.

Lay the outer casing provisionally without adhesive around the internal tube so that the red leather ends exactly at the end of the internal tube. This is how it will be fixed with adhesive. If the hexagonal end of the internal tube does not appear to be robust enough, push the grey end of the ocular tube a short distance inside. Then, as was already done for the outside casings of the objective and ocular tubes, stick the glue tab onto the internal tube so that the bend is on one of the edges. Then continue as in step 4 or 7. Pay parti-

cular attention to ensure that the edge of the outer casing ends precisely at the edge of the internal tube.

Step 14: Round the centre section of the main tube outer casing [C7], bend the glue tab and place it provisionally without adhesive round the internal tube in such a way that the glue tab lies on the same edge as the glue tab of the part that is already secured with adhesive. Then continue with this centre section in the same way as with the first one. Ensure that the two parts abut together without a gap.

Step 15: Then round and bend the third section, the outer casing for the ocular side of the main tube [C8], initially positioning it as a test, and then fixing it in place with adhesive. Here too, the glue tab should lie on the same edge of the internal tube as for the other two outside casing sections. If the hexagonal end of the internal tube is not strong enough, temporarily insert the ocular tube again. Allow the whole item time to dry.

Step 16: For finishing, ring-shaped coverings will be stuck on both ends where the cardboard construction is still apparent. Detach both main tube edge covers 1+2 [C9+C10] from the cardboard. Place them as a test on the ends of the main tube: On the outside they initially protrude by a few millimeters and so they can cover an irregularity in the curvature. Apply adhesive to the open visible cardboard edges of the internal tube and the external casing and place one of the ring-shaped covers on it.

HINT: To facilitate the centring, you could first push the ring onto the grey end of the ocular or objective tube as a helping tool, then push the tube a short distance into the end of the main tube and push the cardboard ring onto the edges to which the adhesive has been applied. Take care: This should stick only the covering of the edge, not the helping tool!

After the adhesive has dried, remove the excess length of the edge covering with a small pair of scissors.

OPTION: Colour the cut edges.

Then do the same with the other edge covering at the other end of the main tube. This completes the main tube.

Section E: **The lens mount of the objective tube**

The main role of the lens mount is to increase the diameter of the objective tube to make room for the objective lens with

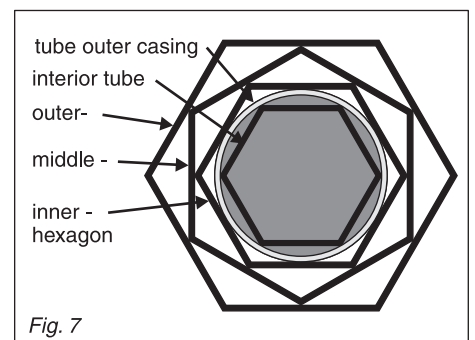

Fig. 7

its 42 mm diameter. This is achieved with three hexagonal tube sections of different sizes, that are pushed and glued together with an offset. The appearance of this from the front is shown in Figure 7. Finally an external circular casing is stuck around this. To protect the objective lens the outer casing protrudes a little, which is why it is wider than the hexagonal parts. However, as was the case with Galileo, only the inner part of the lens is used optically.

Step 17: Detach the inner hexagon of the objective lens mount [A3] from the cardboard, bend to the rear along all the fold lines, and stick the grey marked glue tab behind the opposite end. This gives a hexagonal tube section. Do the same with the middle and outer hexagons [A4+A5].

Step 18: To test, push the inner hexagon [A3] without adhesive onto the grey glue surface at one end of the objective tube so that the tube and the hexagon are flush.

HINT: Do not confuse the objective tube, that is only 97 mm long (3.82 in.) with the ocular tube that is more than twice as long and is not built until the next section.

The centres of the hexagon surfaces are now on the tube and are in contact with it along the length of a line. The hexagon will be stuck along these lines of contact.

Step 19: For this, first push it further along the tube until the surface marked grey is fully exposed. Then as an extension of the lines of contact, apply stripes (not too narrow) of adhesive to the grey surface and rotate the hexagon by 30° so that the lines of contact are now between the adhesive stripes. Push the hexagon back into its first position until it is flush with the tube, with the adhesive not (or only slightly) in contact with it, and rotate it back again: Now the centres of the sides of the hexagon are exactly on the stripes of adhesive. Now check whether the hexagon ends accurately flush with the tube, e.g. by standing it on your working surface, and whether when viewed from the front it is really a regular hexagon. If necessary its shape can be corrected by pressing and pushing.

Step 20: After the adhesive has dried, push the middle hexagon [A4], initially without adhesive, over the inner one and rotate it until the centres of its sides are accurately on the edges of the inner hexagon (see Fig. 7). This is where it will be fixed with adhesive. Then take it out again and bend its sides inwards a little so that it will be firmly located. Apply plenty of adhesive to the edges of the inner hexagon, push the middle hexagon along it and rotate it so that the centres of its sides are on the edges of the inner hexagon. Again, check that this gives a regular hexagon when viewed from the front and that it is flush with the end of the tube and the inner hexagon. Allow it time to dry.

Step 21: Now proceed the same way with the outer hexagon [A5].

Step 22: Round the outer casing of the lens mount of the objective tube [A6] by rolling it on the round rod, and bend the white glue tab forwards and back, and to the rear.

OPTION: Colour the edge opposite the glue tab.

The outer casing is wider than the three hexagon components, so it protrudes at the front. The glue tab does not extend for the whole width but is separated by a cut that is not bent with it (similar to the outer casing of the ocular tube, step 6). As you have already done more than once, first stick the glue tab on to the outer hexagon and ensure that at the tube centre it ends precisely flush with the three hexagon components and protrudes at the front.

Step 23: Round the interior lining of the outer casing [A7] with the aid of the round rod, with the printed side on the inside, and stick it to be flush on the inside of the protruding part of the outer casing.

OPTION: First colour the visible narrow edge.

The projection gives a recessed space that will receive the objective lens in the next step. Then, using plenty of adhesive, stick the edge covering of the objective lens mount [A8] onto the cardboard edges on the other side. This edge covering is also larger than necessary on the outside and the excess will be cut off after drying.

OPTION: Colour the edges of the outer casing after trimming.

Step 24: Clean both sides of the 42 mm objective lens. Look at the lens surfaces from the side to see something reflected in them. One side is planar (flat, giving normal mirror images) and the other is convex (curved outwards, giving reduced-

size mirror images). First, as a trial, place the objective lens with the planar side first into the recess in the lens mount. The curved side then faces outwards and the planar side is on the cardboard edges of the objective tube and the hexagon parts. Stick the lens firmly in this position, by first applying adhesive to the card edges. However, you should omit the adhesive from the centre, so that none of it can reach the clear lens opening. If necessary, carefully move the lens so that its centre is accurately at the centre of the tube. Allow it time to dry.

Step 25: Lastly, stick the outer objective bezel [A9] on to the lens. First check whether it fits in the protrusion of the outer casing and, if necessary, cut off a circumferential shaving.

Step 26: Push the objective tube into the end of the main tube that has more red leather visible between the gold decorations. Push it in to a depth where only about 1 cm of the tube's black leather is still visible. Stick it firmly in this position in the main tube. If it is not tight enough, you can first stick a strip of paper round the concealed end.

Section F: ***The lens mount of the ocular tube***

The lens mount of the ocular tube has a smaller diameter than that of the objective tube, so two hexagon components are adequate here.

Step 27: Detach the inner and outer hexagons of the ocular lens mount [B5+B6] from the cardboard, and bend and stick them as in the previous instructions for hexagon tube sections.

Step 28: Stick the inner hexagon [B5] onto the grey marked end of the ocular tube, using the same method as for the objective tube (steps 18 and 19) and when it is dry stick on the outer hexagon [B6] as in step 20.

Step 29: Round the outer casing of the lens mount of the ocular lens mount [B7] using the round rod, and bend the glue tab.

OPTION: Colour the edge opposite the glue tab.

Stick the tab onto the outer hexagon so that the casing is wrapped round it to the right when viewing the ocular mount from the front. Then stick the other outer casings in the same way as was previously done.

Step 30: Pull the ring-shaped rear edge covering of the ocular lens mount [B8] onto the ocular tube and stick it with plenty of adhesive onto the open visible card edges at the rear of the ocular mount. After drying, cut off the excess length.

OPTION: Colour the edges.

Step 31: Round the interior lining of the ocular lens mount [B9] using the round rod, with the printed side on the inside, and stick it to the inside of the protruding outer casing of the ocular tube. Note that the edges must be flush at the front.

Step 32: Clean the ocular lens and place it, initially without adhesive, in the recess at the front of the lens mount with the planar (flat) side first. The convex side (curved inwards) faces outwards, towards the eye. Take the lens out again, apply adhesive to the card edges where the lens will make contact with them, and carefully insert the lens again. Be particularly careful to ensure that no adhesive gets into the field of vision of the lens. If necessary, carefully adjust the position of the lens so that its centre is accurately at the centre of the tube opening. Allow it time to dry.

Step 33: Check whether the outer lens bezel [B11] can be easily placed on the lens or whether a little still needs to be cut off the outer edge. Then carefully stick it to the outer edge of the lens with a few small drops of adhesive.

Step 34: Stick the front lens covering of the ocular lens mount [B10] onto the lens mount at the front and, after the glue has dried, cut off the excess length.

OPTION: Colour the edges.

With the ocular tube, the whole telescope is now complete and you can take your first look through it. Do not be disappointed that the image section is so small! It is precisely this that is an unavoidable property of telescopes with this arrangement of lenses. 400 years ago Galileo Galilei had to cope with even smaller images with his telescopes that had greater magnifications. Despite this he made groundbreaking discoveries with them, but with the help of a stand which avoided magnifying the slight, normally unnoticeable, trembling movements of the hand.

HINT: If you fix a tripod adapter (e.g. item 258.FSR from AstroMedia) to the telescope with elastic bands or masking tape, you can mount it on any standard camera tripod.

Section G:

The telescope holder

The holder consists of 6 parts: The rear panel [D1] (which extends into the base and the front face), the front part [D6] (with the circular channel into which the telescope fits), the two reinforcement rings [D2+D3] that are stuck between the rear wall and the front part and the two side pieces [D4+D5]. The holder can stand on a table or be hung on the wall. In the latter case the holes on which it is hung require internal reinforcement before the holder is assembled.

Step 35: Detach the rear panel of the holder [D1] from the cardboard, write your name in the area provided and apply the letter markings A, B, C, D and E to the back (see Fig. 8). This will simplify assembling the side pieces.

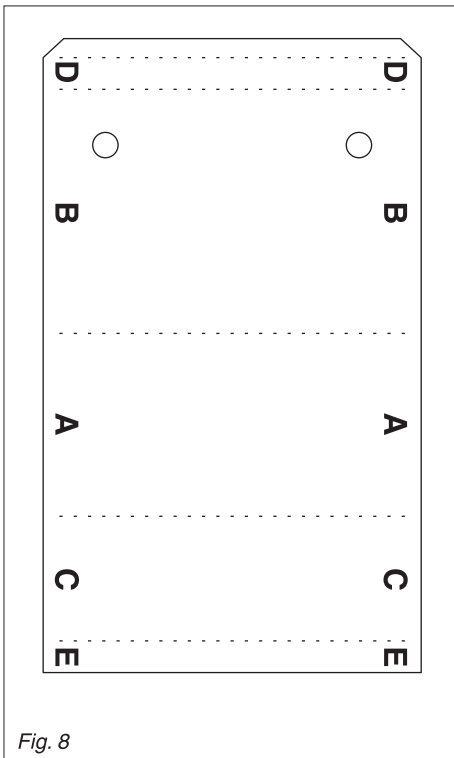

Fig. 8

Step 36: If you want to prepare the holder for hanging on the wall, detach the two pre-punched discs from the red leather to make the holes. Then stick washers made of metal or similar material onto the back around the holes to prevent the cardboard from tearing. The holes in the washers need to be big enough for the nails or screws in the wall and must be flush with the top edges of the holes in the cardboard. If you do not wish to allow for wall mounting, you can leave the punched discs in place and apply adhesive tape over them on the back to prevent them from falling out.

Step 37: Fold the rear panel to the back along all the fold lines. This will give the actual rear side (marked with B), the base (A), the front face (C) and two narrow ledges (D and E).

Step 38: Detach the two rear-panel reinforcement rings [D2+D3] from the cardboard; these are the last parts from sheet 2. Bend both strips into a circle and stick them with about 5 mm overlap to make rings having a diameter of nearly 30 mm and 10.5 mm width. Apply plenty of adhesive to the edges of the rings on one side and stick them on the back of the rear panel around the suspension holes. The front of the holder [D6] will later be stuck to the front edges.

Step 39: Detach the left side piece of the holder [D4] from the cardboard and bend all the glue tabs back. This should give a smooth round shape from the folds of the small tooth-shaped glue tabs. First, to test it, place the side piece into the left half of part D1 so that the same letter markings of the side piece and the rear panel are next to each other, and then stick the A and B tabs to the part [D1]. Push the side piece firmly into the corner between the A and B edges and ensure that it is flush with the edges.

Step 40: In a similar way, stick the right-hand side piece [D5] with tabs A and B to the right of part [D1] and then also stick the C and D glue tabs firmly on both sides. For this, you might need to crease the D ledge again.

Step 41: Detach the front part of the holder [D6], the last part of the kit, from the cardboard. Bend the glue tab back and use the round rod to give a round shape to the bottom 5.5 cm of the front part (this is in effect the part under the panel with the words "Replikat...", and the same amount above it). This round shape of the front part needs to match the round shapes of the two side pieces. As a test, place the rounded end into the side pieces with the Galileo portrait protruding upwards and the glue tab under the ledge marked E. Then, first stick the glue tab under the ledge E and allow the glue to dry. Then apply glue to the remaining glue tabs and carefully press the ledge and the rear panel onto them.

Congratulations! Your historical cardboard replica of Galileo Galilei's telescope is complete, including the holder.

You can use this telescope to make observations, but the small field of view will make this as laborious as it was in Galileo's time. If you would like to make yourself a modern powerful telescope with lens optics like those of Kepler or mirror optics like those of Newton, you will find the appropriate kits in our catalogue and on our Web site.

AstroMedia UK
Landell, Brick Kiln Lane
Ingham, Norwich
NR12 9SX

+44 (0) 7864 912372

www.AstroMediaShop.co.uk